

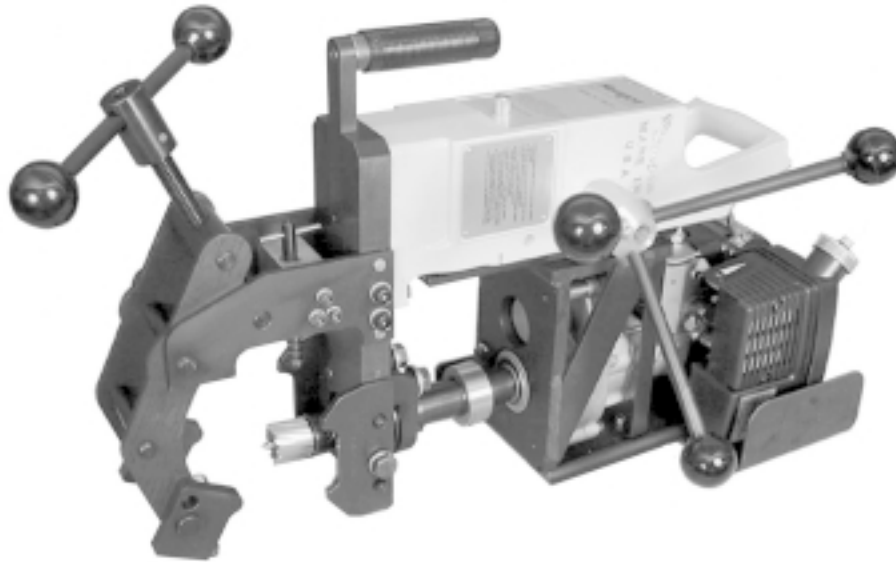

OPERATOR'S MANUAL MODEL 10927A



**PORTABLE GASOLINE RAIL DRILL --- MANUAL FEED
70 LB. A.S.C.E. TO 155 LB. P.S.**

Index

Model 10927A Features	Page 3
Welcome to TRAK-STAR	3
Unpacking Your New Rail Drill	3
Important Safety Instructions	4
Model features	5
Pre-Operation Instructions (Engine)	6
Positioning of Hole Location Template	7
Drill and Pressurized Coolant System	8
Important Notice	9
Clamping Procedures	10
Adjustment of Gibs	11
- - Front Support Bracket Adjustment	11
- - - Installing / Replacing Cutter	11
Rail and Shoe Data	12
Operating Instructions	13
10927A Exploded View	14
Parts List	15
Engine Parts Diagram and parts	16
Maintenance - - Engine	17
Maintenance - - Drill	17
Hints for Smoother Operation	18
Super Concentrate Cutting Fluid	18
“15,000-Series” Cutters	18
Other Products offered by Trak-Star	19
Commercial / Industrial Warranty	
- Factory Authorized Repair Centers	
- - Hougen Patent Notice	

TRAK-STAR® Portable Gas Rail Drill

Model 10927A

Welcome to Trak-Star

Congratulations on your purchase of the Trak-Star Portable Gas Rail Drill. Your model is designed to produce superior holes quickly and efficiently. Through constant innovation and development, Trak-Star is committed to provide you with hole-producing tools and products that lead the industrial world.

Before attempting to operate your new Rail Drill, please read all instructions first. These include the Operators Manual and warning Label on unit itself. With proper use, care, and maintenance, your model will provide you with years of effective hole drilling performance. Once again, thank you for selecting our product and welcome to Trak-Star.

Unpacking Your New Rail Drill

1. Open shipping carton and remove the literature and hardware packages.
2. Read and Follow All Instructions before attempting to operate your new Rail Drill. A CD has been also supplied for your convenience.
3. Complete and mail the Product Registration Card **NOW**. It is important that Hougen Manufacturing, Inc., have a record of product ownership.
4. Open hardware package and check contents.
 - 03161 Feed handles (3)
 - 10570 Feed handle knobs (3)
 - 10565 Hex-Key 1/8"
 - 10727 Wrench-Allen 3/16"
 - 04149 Wrench-Allen 7/32" T
 - 01293 Wrench-Allen 3/32
 - 03635 Pilot
5. Lift Rail Drill out of shipping carton using drill housing handle and clamp handle
6. Screw the three knobs (10570) into the three feed handles (03161) and then screw the handle into the Hub Assembly (03177)
7. Your new Rail Drill was factory adjusted prior to shipping. Check to make sure that all gib adjustment screws, motor hold-down screws, front support bracket screws, drill housing and shoe mounting screws are snug and have not vibrated loose in transit.
8. Remove Coolant Bottle / Hose Assembly (01592) from the separate shipping container. Connect the quick-disconnect hose fitting to the Rail Drill. See Procedure on page 5.
9. Reread Safety Warnings listed in this Operator's Manual and on the drill unit to avoid injury. Follow operating procedures.

Your new Rail Drill is equipped with a 3/4" diameter arbor bore to accept "15,000-Series" style TRAK-STAR cutters. Order cutters separately. Install pilot inside cutter before attaching cutter to arbor (see Procedure page 9)

Important Safety Instructions

1. **Read all Instructions**
2. **Keep Work area clean**
Cluttered area and benches invite injuries. Keep dirt and chips from under TRAK-STAR cutter area and drill shoe.
3. **Consider Work Area Environment.**
Keep work area well lit.
4. **Keep Children Away**
Do not let visitors contact tool.
5. **Store Idle Tools**
When not in use, tools should be stored in a dry, and a high or locked-up place -- out of reach of children.
6. **Do Not Force Tool**
It will do the job better and faster at the rate for which it was intended.
7. **Use Right Tool**
Do not force small tool or attachment to do the job of a heavy duty tool.
Do not use tool for purpose not intended -- for example do not use a circular saw for cutting tree limbs or logs.
8. **Dress Properly**
Do not wear loose clothing or jewelry. They might entangle with spinning chips or get caught in moving parts. Rubber gloves and non-skid footwear are recommended when working outdoors. Wear sturdy leather gloves when working indoors.
9. **Always Wear Safety Glasses or Goggles.**
10. **Do Not Overreach**
Keep proper footing and balance at all time.
11. **Secure Work**
Clamp work securely using appropriate shoe size and shape.
Tighten Clamp by using two hands with handle placed in central position and tighten securely.
12. **Maintain Tools With Care**
Keep tools sharp and clean for better and safer performance.
Do not use dull or broken TRAK-STAR cutters. Follow instructions for lubricating and changing accessories. Inspect gas line periodically and, if damaged, have repaired by authorized service facility.
Keep handles dry, clean, and free from oil and grease.
13. **Disconnect Tools**
Disconnect spark plug wire from spark plug when not in use, before servicing, and when changing TRAK-STAR Cutters or accessories.
14. **Remove Adjusting Keys and Wrenches**
Form a habit of checking to see that keys and wrenches are removed from tool before turning drill unit on.
15. **Stay Alert**
Watch what you are doing. Use common sense. Do Not operate tool when you are tired.
16. **Check Damaged Parts**
Before further use of drill, a part that is damaged should be carefully checked to determine that it will operate properly and perform its intended function.
Check for alignment of moving parts, binding of moving parts, breakage of parts, mounting, and any other conditions that may affect its operation.
A part that is damaged should be properly repaired or replaced by an authorized service center unless otherwise indicated elsewhere in this instruction manual.

Do not use Rail Drill if starting the motor does not turn arbor.

A part that is damaged should be properly repaired or replaced by an authorized service center unless otherwise indicated elsewhere in this instruction manual.
17. **Additional Safety Precautions**
 - Arbor and cutter should never be used as a handhold.
 - Keep hands and clothing away from all moving parts.
 - Do not use TRAK-STAR cutters where ejected slug might cause injury (slug ejected at end of cut).
 - Be sure that all safety devices are properly adjusted and in use. Also, adhere to all operating instructions.
 - Do not attach Rail Drill to live 3rd rail track.
18. **Non-Conforming Cutting Tools**
The TRAK-STAR Model 10927A is designed to use TRAK-STAR "15,000-Series" Cutters only. The use of drilling tools having different shank styles is not recommended as they may not tighten securely in the TRAK-STAR arbor with risk of accident or injury.
19. **Save These Instructions**

Model 10927A Features

IMPORTANT: Before starting the machine, it is imperative that the operator know and understand instructions for safe operation, correct operation procedures and interaction of other related features.

Ignition switch located on engine---stops spindle and cutter rotation. See diagram at right.

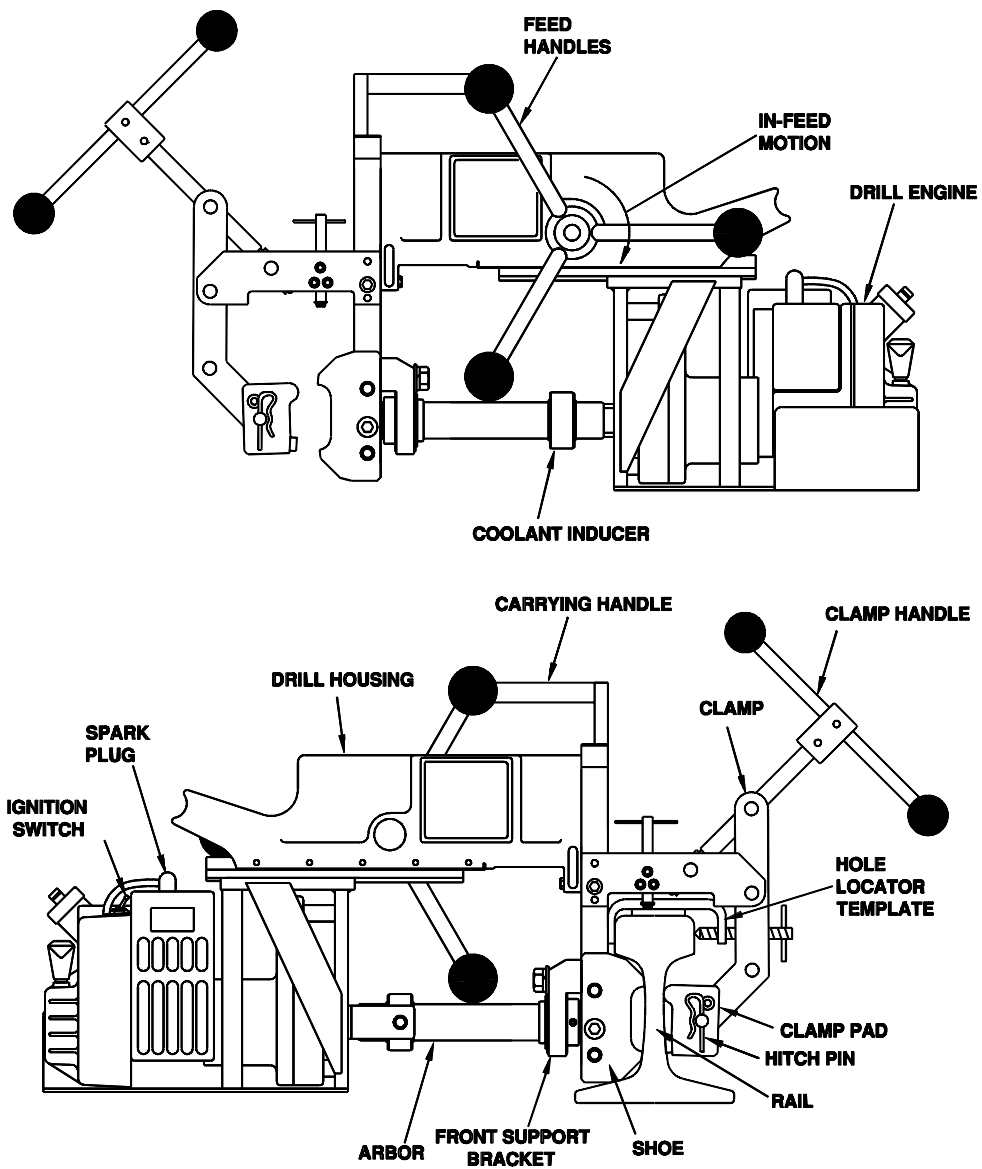
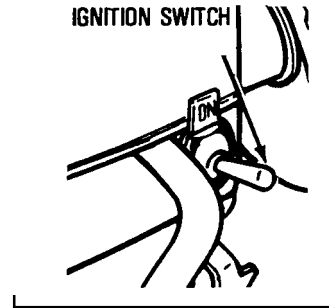

Pre-Operation Instructions

Engine

THIS SYMBOL POINTS OUT IMPORTANT SAFETY INSTRUCTIONS WHICH IF NOT FOLLOWED COULD ENDANGER THE PERSONAL SAFETY AND/OR PROPERTY OF YOURSELF AND OTHERS. READ AND FOLLOW ALL INSTRUCTIONS IN THIS MANUAL AND ANY PROVIDED WITH THE EQUIPMENT ON WHICH THIS ENGINE IS USED BEFORE ATTEMPTING TO OPERATE YOUR TECUMSEH ENGINE.

THESE SYMBOLS MAY APPEAR ON THE ENGINE:



FUEL MIX CHART Mixture 24:1			
U.S.		S.I. (Metric)	
GAS	Oil to be Added	GAS	Oil to be Added
1 Gal.	5 oz.	4 Liters	167 ml.
2 Gal.	11 oz.	8 Liters	333 ml.
5 Gal.	27 oz.	20 Liters	833 ml.

1. Use a clean, high quality 2-Cycle oil. Tecumseh specially formulated oil is available at any Authorized Tecumseh Service Outlet. Order as part number 730227. **Do not use multi-viscosity oils. Disregard mix ratio instructions on all containers if instructions conflict with Fuel Mix Chart on this page.**

2. Use fresh, clean unleaded regular automotive gasoline. Leaded regular and unleaded or leaded premium grades of gasoline are acceptable substitutes. Note: Do not use gasoline containing methanol (wood alcohol). Gasoline containing up to 10% ethanol or grain alcohol "Gasahol" may be used but requires special care when engine is unused for extended periods.

3. Mix oil & gasoline by filling an approved, clean container one quarter full with recommended gasoline. Add recommended oil to gasoline per Fuel Mix Chart on this page. **Do not mix directly in engine fuel tank.** Screw cap on container and shake vigorously. Then unscrew cap and fill container as shown in Fuel Mix Chart. Once mixed, oil and gasoline will not separate.

Never mix or store gasoline/oil mixture indoors or in enclosed, poorly ventilated areas, where fuel fumes may reach an open flame, spark, or pilot light as on a furnace, water heater, clothes dryer or other gas appliance.

4. READ ALL INSTRUCTIONS PROVIDED WITH THE EQUIPMENT ON WHICH THIS ENGINE IS USED.

5. Fill fuel tank by first cleaning area around fuel fill cap and then remove cap. Add Fuel Mix specified as preceding Item #3. Use a funnel to help avoid spillage. Never use "stale" gasoline stored for long periods. Install fuel fill cap and wipe away any spilled Fuel Mix.

Never fill fuel tank indoors, never fill fuel tank when engine is running or hot. Do not smoke when filling fuel tank.

Never fill fuel tank completely. Fill tank to 1/2" below bottom of filler neck to provide space for fuel expansion.

Wipe any fuel spillage from engine and equipment before starting engine.

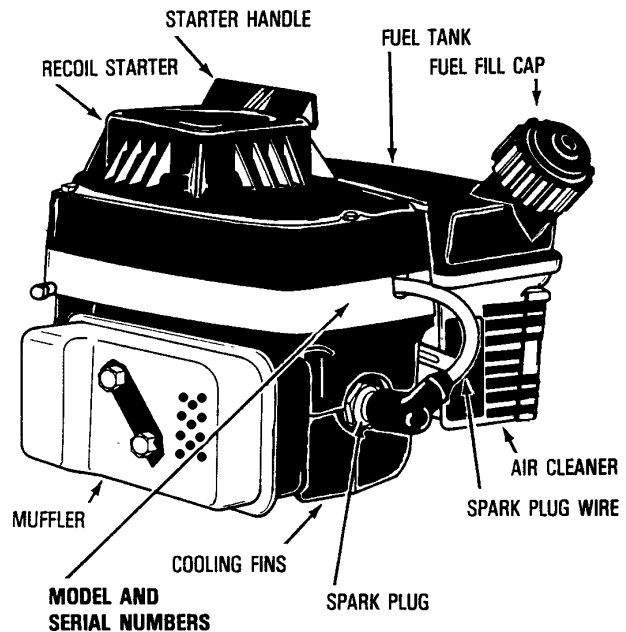

Figure 5

6. Check the following:
Be sure spark plug wire is attached to spark plug (see Figure 6)

Be sure any ignition switch on engine or equipment is in "ON", "RUN", or "START" position (see Figure 6)

Be sure air vent on fuel fill cap is free of debris and air vent screw (Fig. 6) is open.

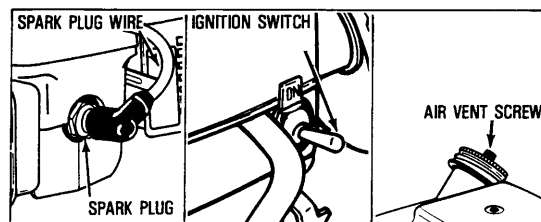

Figure 6

Positioning of Optional Hole Location Template

Template is positioned on head of rail with tapered tip flush with end of rail and side locking screws fastened to rail head. Notches in template give precise location of hole centerlines to be drilled.

The rail clamp assembly has a locating pin which rests in the template notches. The locating pin is adjustable to accommodate the full range of rail sizes.

To use the locating pin, first make sure the pin is in its highest position and locked. The pinhandle should be perpendicular to the rail. Raise the drill unit over the rail with the template attached and gently rest drill down until shoes make contact with the rail. Release the pin by turning handle a quarter turn, making the handle parallel with the rail. Slowly slide rail drill across the template until the pin falls into notch.

The pin must contact the sides of the matching notch and can touch the bottom of the notch. Following the Clamping Instructions, clamp unit onto rail. When the hole is completed, raise the pin by the handle and turn a quarter turn to lock pin into position. To drill the next hole, move the drill sideways, ensuring the pin is clear of the notch, and release pin. Slide the drill sideways until pin falls in the next notch, and repeat the procedure as necessary.

Note: The locating pin must be in its uppermost and locked position before putting the drill unit on the rail. Failure to do so can result in damage to the hole locating pin system.

Hole location templates are offered as optional equipment. Four of these templates are provided with established hole spacings. The 40570 template is produced to customer specified hole spacing. See chart for the template to match your application.

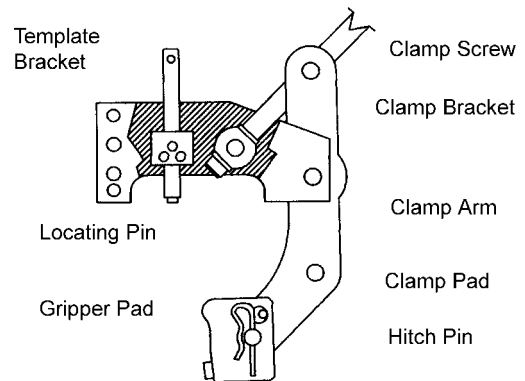
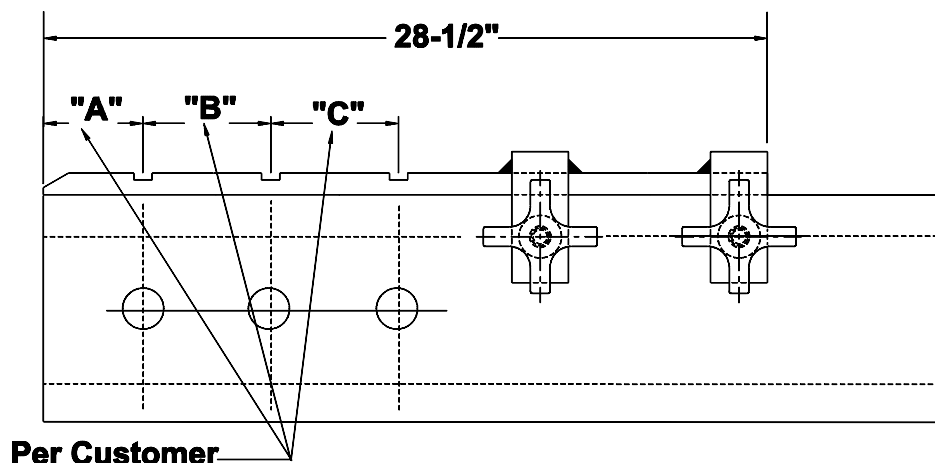

Figure 10

Template Part No.	Hole Spacing
40570	Customer Specified
40701	3-1/2" x 6" x 6"
40702	2-11/16" x 5-1/2" x 5-1/2"
40703	2-1/2" x 5"
40704	2-1/2" x 6-1/2" x 6-1/2"

Fig 9 Template 40570



Drill & Pressurized Coolant System

1. Install correct shoes for rail type being drilled.
2. Install correct size TRAK-STAR Cutter with pilot pin and secure to drill arbor with set screw(s). See Cutter Installation procedure.
3. Fill coolant bottle with TRAK-STAR cutting fluid (a water soluble and biodegradable product) or equivalent. Conventional fill access is achieved by removing pump handle. Caution: Contents under pressure. Partially open to slowly release pressure before removing. A quick-fill access is also provided at the quick disconnect auxillary hose port. This feature is intended for use when dispensing coolant from large drums with a hand pump.
4. Attach coolant bottle quick connect hose fitting to drill arbor at inducer fitting.
5. Pressurize coolant bottle (approximately 20 pumps)
6. Partially open coolant shut off valve.
7. Depress pilot pin approximately 1/4" and watch for coolant flow from the end of the cutter. NOTE - Coolant is under pressure -- stay out of path of spray. If coolant does not flow, rotate valve further to open or unclog coolant system.
8. Shut off coolant valve.



Figure 4

IMPORTANT NOTICE

READ THIS

1. Make sure cutter is properly installed.
(See instructions for installing TRAK-STAR Cutter in arbor)
2. The #1 cause of premature cutter failure is improper clamping. Read, understand and follow clamping procedures on the next page.
3. The #2 cause of premature cutter failure is improper feed, usually feeding too slow.
4. Always use caution in contacting the rail with the cutting tool. Allow the cutter to completely enter the rail before applying full feed pressure.
5. Do not force tool at the end of cut. Reduce manual feed pressure prior to break-through on the rail and allow the cutter to work.

The TRAK-STAR 10927A Gasoline Rail Drill in conjunction with the TRAK-STAR cutting tool provides you with the most efficient lightweight rail drilling system available. This new cutting technology will be most successful when the operator understands the above mentioned instructions.

CLAMPING PROCEDURES

WARNING: IMPROPER CLAMPING WILL CAUSE PREMATURE CUTTER FAILURE

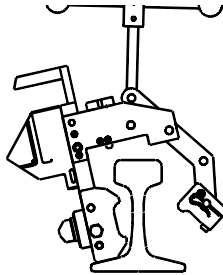

STEP #1:

WITH CLAMP IN OPEN POSITION, REST UNIT ON RAIL BASE. BOTTOM OF SHOES SHOULD CONTACT TAPER ON RAIL BASE. **(SEE FIG. A)**

**** PERFORMANCE TIP: CLOSE CLAMP UNTIL CLAMP PAD CONTACTS WEB OF RAIL PRIOR TO STEP #2.**

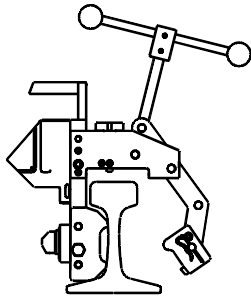

STEP #2:

RAISE REAR OF RAIL DRILL TO LOCATE SHOES IN PROPER POSITION. **(SEE FIGURE B)**

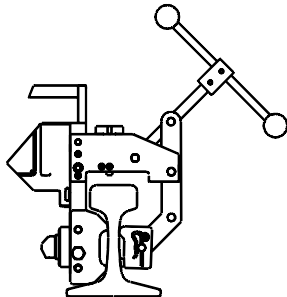

STEP #3:

WHILE MAINTAINING CONTACT BETWEEN SHOES AND RAIL, TIGHTEN CLAMP. **(SEE FIG. C)**

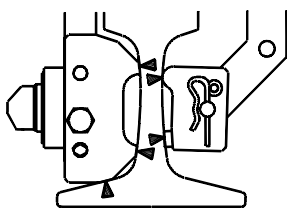

INDICATES CONTACT POINTS

STEP #4:

WHEN UNIT IS FIRMLY CLAMPED, CHECK FOR PROPER SHOE AND PAD CONTACT ON BOTH SIDES **(SEE FIG. D)**

Adjustment of Gibs

Loosen all front support locking screws and bolts prior to adjusting gibs.

1. Loosen Hex nuts (10563) and Set Screws (10958).
2. Feed the drill in and out a few times and then, with top of motor slide flush with top of housing, tighten the Gib Screws until you feel them touch the Steel Gib (40225).
3. Feed the drill in and out again.
4. Adjust Gib Screws so that there is uniform pressure from top to bottom. (Top of motor slide flush with top of housing)
5. Turn each Gib Screw in equally about 1/8 to 1/4 turn, depending upon your preference.
6. Gib Screws should be tight enough so that slide moves in and out smoothly with no wobble or shaking. (Looseness will cause cutter breakage)
7. Without rotating Allen Wrench in Set Screw, tighten each Hex Nut.

Note: Gibs should be lubricated regularly.

Front Support Bracket Adjustment

Adjust Gibs before adjusting front support bracket.

1. Loosen Side Locking Screws (10623)
 2. Loosen arbor support bracket bolts (03690)
 3. Be sure top of arbor is flush with the shoulder on motor output shaft. Also make certain arbor is securely fastened.
 4. Turn feed handle until motor and spindle are at the bottom of their travel.
 5. Tighten Front Support Bolts. recommended torque 80 ft/lbs. (Use Loctite 242 if possible)
 6. Feed slide in and out a few times, checking for free and uniform movement.
 7. Tighten Side Locking Screws. Do Not over tighten.
- Note:** Check front support bolts regularly to make certain they are tight. Tighten as required.

Installing / Replacing TRAK-STAR Cutter In Arbor

1. Disconnect spark plug wire from spark plug. Turn off coolant at shut-off in the case of replacing a cutter. The spring seat system located within arbor was not designed to be 100% leak proof.
2. Lay drill on its side with feed handles up.
3. Position slide so the side locking screws (40222) on arbor are accessible. Loosen and remove screws. Remove cutter in case of replacement. Do not depress pilot pin during procedure to release seal. Doing so will result in releasing pressurized contents of arbor cavity and coolant loss. Some loss, however, is normal due to cavity between cutter shank and spring seat.
4. Insert pilot in shank end of TRAK-STAR cutter.
5. Insert TRAK-STAR cutter until flats on cutter shank are aligned with set screw holes and are exactly perpendicular to axis of set screw holes of removed screws. (do not depress pilot in case of cutter replacement for reason noted in #3.
6. Insert set screws and tighten. Make sure cutter is secure.

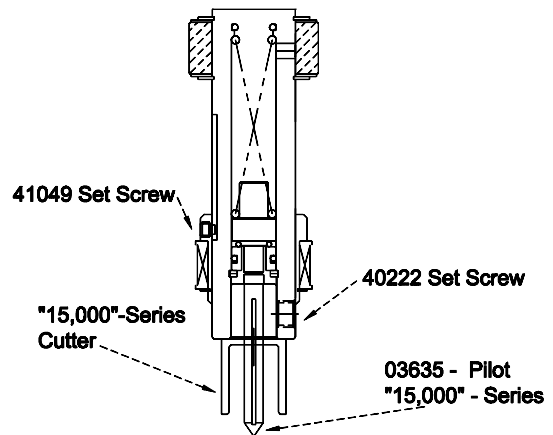

Figure 12

Rail & Shoe Data

Railway Association or System	Tee Rail Section, lb.	Section Designation	Shoe Part Number
A S C E American Society of Civil Engineers	70	7040 70 AS 701	01906
	75	7540 75 AS 753	01907
	80	8040 80 AS 800	01908
	85	8540 85 AS 851	01909
	90	9040 90 AS ---	01910
	100	10040 100 AS ---	01911
A R A American Railway Engineer Association	Type "A" - High Rail for High Speeds		
	90	9020 90 RA 902	01927
	100	10020 100 RA 1003	01928
	Type "B" - Low Rail for Heavy Loads at Slower Speeds		
	90	9030 90 RB 905	01908
	100	10030 100 RB 1002	01910
A R E A American Railway Engineer Association	100	10025 100 RE 10025	01894
	110	11025 110 RE 1100	01895
	112	11228 112 RE 1100	01896
	115	11525 115 RE 1150	01897
	119	11937 119 RE 1190	01897
	130	13025 130 RE 1300	01898
	131	13128 131 RE 1311	01899
	132/136	13228 132 RE 1321	01902
	133	13331 133 RE 1330	01901
	136/132	13622 136 RE 13637	01902
	140	--- 140 RE ---	01903
	CSX	122	--- 122 CG ---
C & NW Chicago & Northwestern	100	10035 100 DM 10035	01926
P S Pennsylvania System	85	8531 85 PS ---	01912
	100	10031 100 PS ---	01913
	130	13031 130 PS ---	01914
	155	15531 155 PH ---	01919
NYC (Dudley)-New York Central & Hudson River Railroad	105	10524 105 DY ---	01915
	127	12723 127 DY ---	01916
PRP Pennsylvania Railroad	85	8533 85 PR ---	01917
Consult Hougen Technical Sales	141	141 AB	04205

Operating Instructions

⚠ **NEVER RUN ENGINE INDOORS OR IN ENCLOSED, POORLY VENTILATED AREAS. ENGINE EXHAUST CONTAINS CARBON MONOXIDE, AN ODORLESS AND DEADLY GAS.**

⚠ **KEEP HANDS, FEET, HAIR, AND LOOSE CLOTHING AWAY FROM ANY MOVING PARTS ON ENGINE AND EQUIPMENT.**

⚠ **WARNING - TEMPERATURE OF MUFFLER AND NEAR BY AREAS MAY EXCEED 150°F (65°C). AVOID THESE AREAS.**

Perform procedures in Pre-Operation Instructions.

1. Make sure workpiece, cutter and shoe surfaces are free of chips, etc.
2. Place locator template on rail head.
3. Align drill on locator per Positioning of Optional Hole Location template.
4. Clamp drill to rail and insure proper (5) point contact.
5. Turn on coolant (pump to pressurize system).
6. Move choke lever to "FULL CHOKE" (See diagram). If restarting a warm engine after a short shutdown, move choke lever to "NO CHOKE".
7. Grasp starter handle and pull rope out, slowly, until it meets resistance. Let rope rewind slowly. Then pull rope with a rapid full arm stroke. Let rope return to starter slowly.
8. Repeat step #7 until engine fires. When engine starts, move choke lever to "1/2 CHOKE" until engine runs smoothly and then to "NO CHOKE". If engine falters, move choke lever back to "1/2 CHOKE" until engine runs smooth and then to "NO CHOKE". NOTE: If engine fires, but does not continue to run, move choke lever to "NO CHOKE" and repeat #7 until engine starts.
9. Manually feed cutter and very gently start cutting. Generally, the rail drill will vibrate slightly at the beginning of the cut. This is due to cutting on a radius. The drill will run smooth once the cutter starts to cut a complete circle.
10. When the drill starts to run smooth, aggressively feed tool through workpiece at an even rate. Do not overload unit to induce an arbor stalling situation. Certain rail compositions workharden easily. Do not pause during cut nor release feed pressure if changing hand grip on feed handles. This will result in premature cutter wear and drilling problems while in the cut.

12. Turn feed handles to retract arbor and cutter.

13. At the end of the cut, move ignition switch on engine to "STOP" or "OFF" position.

14. Close air vent screw on fuel fill cap.

15. Remove or loosen clamp. Slug should eject from spring loaded pilot pin pressure. Drill cycle is complete and you are ready to go on to the next hole. Shutting off coolant after use is suggested, if use is intermittent.

If Slug Has Not Fallen Free, disconnect spark plug wire from spark plug and shut off coolant supply. Use a screwdriver to carefully flip slug by inserting it between slug flange and cutter gullet. It generally will remove easily while discharging a squirt of coolant. Avoid prying with force, damage to the cutter and cutting edge may result.

⚠ **WHEN EQUIPMENT WILL NOT BE USED FOR EXTENDED PERIODS, DISCONNECT SPARK PLUG WIRE FROM SPARK PLUG AND KEEP IT AWAY FROM SPARK PLUG.**

⚠ **NEVER STORE ENGINE WITH FUEL IN TANK INDOORS OR IN ENCLOSED, POORLY VENTILATED AREAS, WHERE FUEL FUMES MAY REACH AN OPEN FLAME, SPARK, OR PILOT LIGHT AS ON A FURNACE, WATER HEATER, CLOTHES DRYER OR OTHER GAS APPLIANCE.**

FIGURE 7

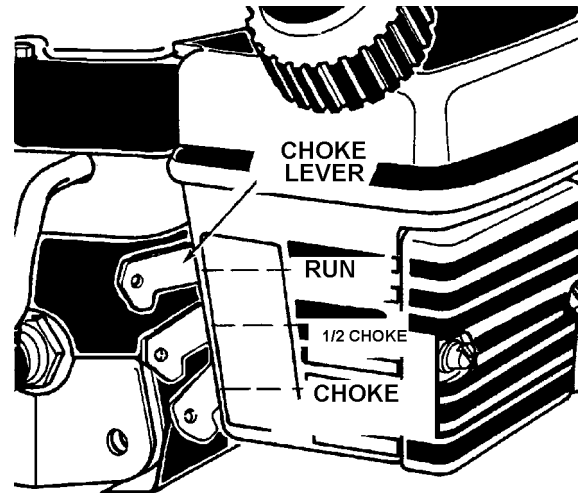
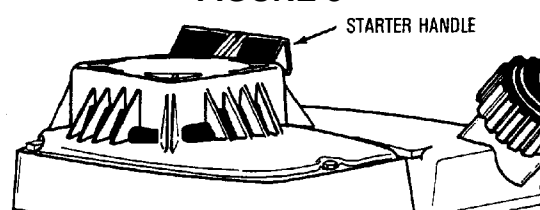
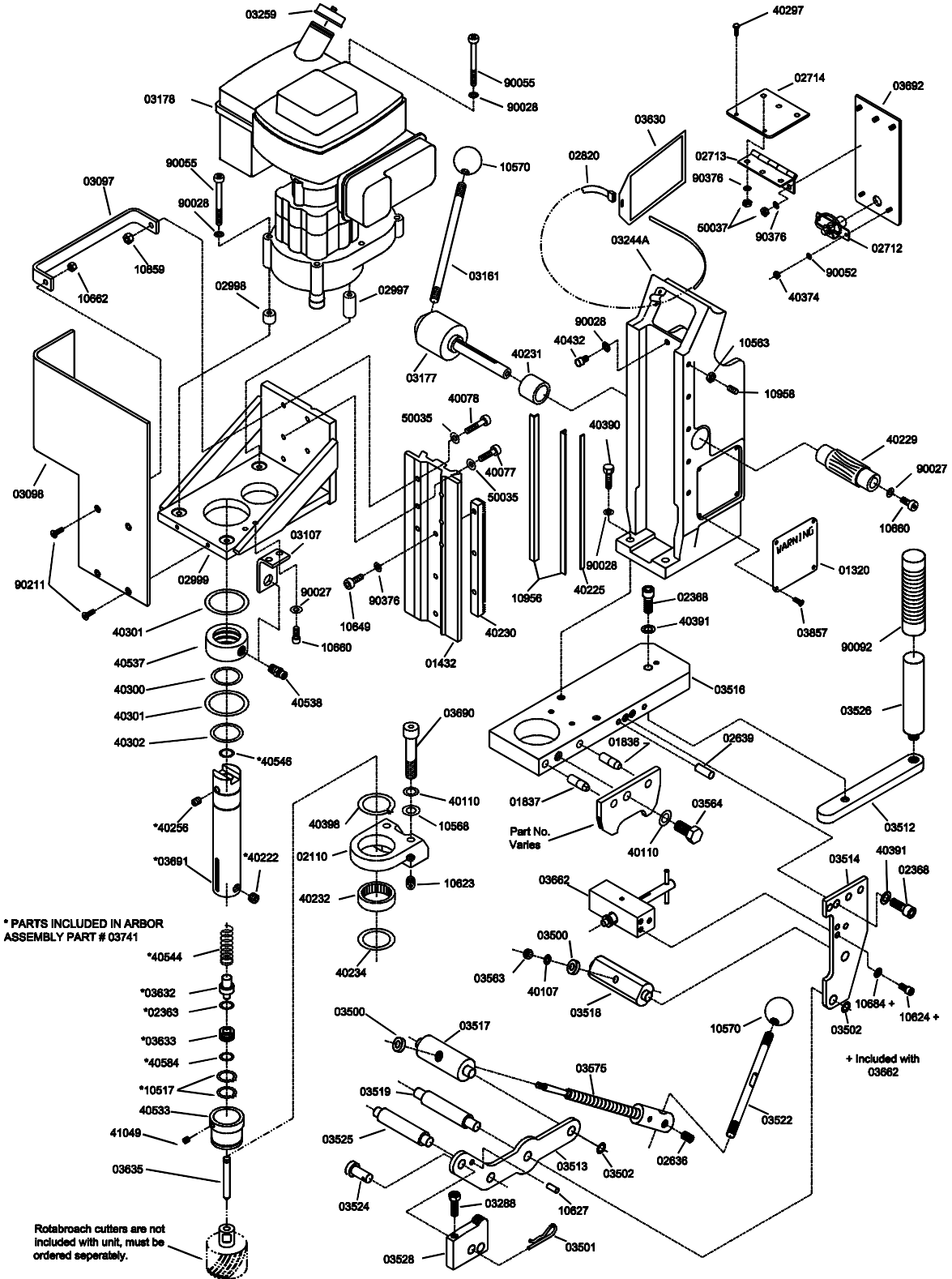

FIGURE 8



10927A Exploded View



Parts List -- Model 10927A

Part No.	Description	Qty.	Part No.	Description	Qty.
Various	Shoe (see Rail & Shoe Data)	1 Pair	03741	Arbor Assembly	1
01320	Warning Tag	2	03857	Drive Screw	8
01432	Slide	1	04349	Set Screw 1/4-28	5
01569	Coolant Shut-Off Valve	1	10517	Retaining Ring	2
01570	Quick Connect Fitting	1	10563	Hex Jam Nut	5
01592	Coolant Bottle	1	10568	Flat Washer	2
01593	Hose Clamp	2	10570	Feed Handle Knob	3
01836	Round Locating Pin	2	10623	Set Screw	2
01837	Diamond Locating Pin	2	10649	Screw #10-32	3
02110	Front Support Bracket	1	10660	Screw 1/4-20	3
02363	O-Ring	1	10662	Lock Nut #10-24	2
02368	Screw 3/8-16	3	10841	Scr-SHC #10-24	2
02636	Screw 3/8-16 x 1/2	1	10859	Jam Nut	2
02712	Spring Latch	1	10956	Brass Gib - Pair	1
02713	Hinge	1	40077	Screw - 1/4-20	1
02714	Panel Plate	1	40078	Screw 1/4-20 x 1-1/2	2
02820	Tie cable	1	40107	5/16 HCLW	1
02997	Spacer	2	40110	Lock Washer 1/2	2
02998	Spacer	2	40222	Set Screw 7/16	2
02999	Engine Bracket	1	40225	Steel Gib	1
03097	Brace	2	40229	Feed Gear	1
03098	Shkid Plate	1	40230	Rack 20 Pitch	1
03107	Strap	1	40231	Bronze Bushing	2
03161	Feed Handle	3	40232	Roller Bearing	1
03177	Hub Assembly	1	40234	Thrust Washer	2
03178	Gas Engine	1	40256	Set Screw 5/16-18	1
03244A	Housing	1	40296	Seal Neop.	1.5 FT
03288	Gripper	2	40297	Screw #6-32	2
03500	Washer Machine	2	40300	"O" Ring	2
03501	Hitch Pin	2	40301	Thrust Washer	2
03502	Retaining Ring	6	40302	Retaining Ring	2
03512	Clamp Carry Arm	1	40374	Hex-Nut #6-32	2
03513	Clamp Arm	2	40390	Bolt - 1/4-20	3
03514	Clamp Bracket	2	40391	Lock washer 3/8	3
03516	Base Plate	1	40398	Retaining Ring	1
03517	Clamp Round Bushing	1	40432	Scr-SHC 1/4-28	1
03518	Clamp Flat Bushing	1	40533	Ejector Collar	1
03519	Clamp Middle Pin	1	40537	Coolant Inducer	1
03522	Clamp Turn Handle	1	40538	Quick Connect Nipple	1
03524	Clamp Short Pin	2	40544	Spring	1
03525	Clamp Lower Pin	1	40546	"O" Ring	1
03526	Clamp carrying Handle	1	40584	"O" Ring	1
03528	Radiused Clamp Pad	2	41049	Set Screw	1
03563	Hex Nut 5/16	1	50035	Lock washer	6
03564	Screw 1/2-13	2	50037	Hex Nut	6
03575	Clamp Feed Screw Assy.	1	90027	Flat Washer	3
03630	Clamping Procedure Tag	1	90028	Lock washer	9
03632	Spring Seat	1	90052	Lock Washer	2
03633	O-Ring Washer	1	90055	Screw 1/4-20	4
03662	Clamp Template Scr.	1	90092	Carry Handle Grip	1
03690	Bolt 1/2-20	2	90211	Screw #10-24	4
03691	Arbor-Gas Drill	1	90376	Lock washer	9
03692	Faceplate	1			

Engine Parts Diagram

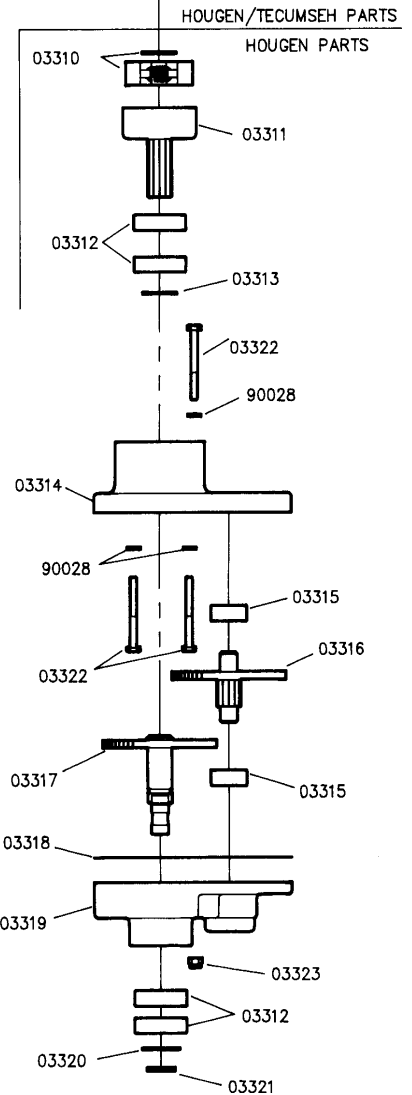
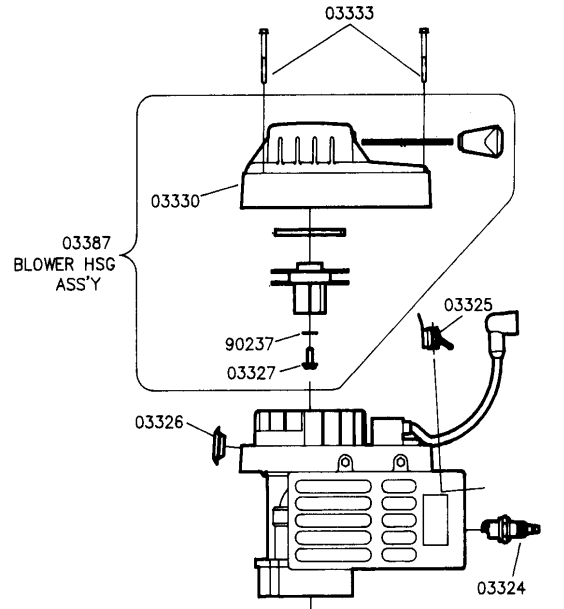
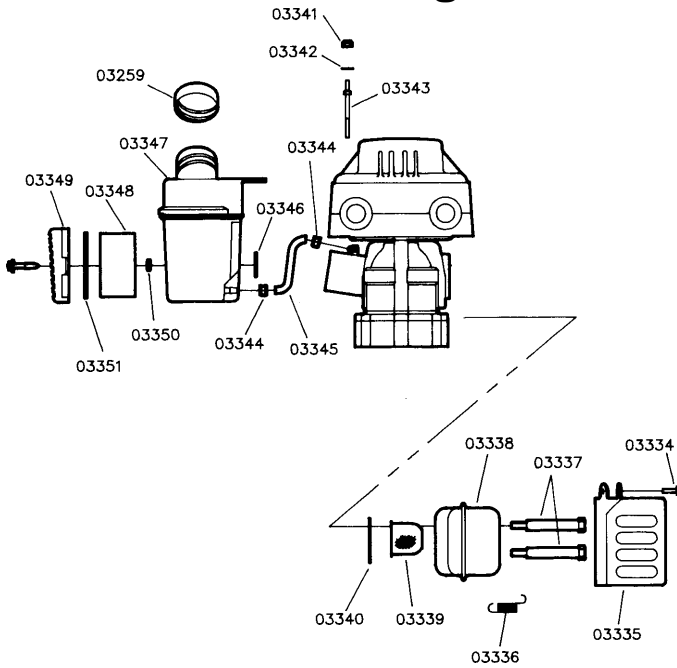

Hougen Part No.	Description	No Req'd.	Hougen Part No.	Description	No. Req'd.
03259	Vented Fuel Cap	1	03336	Muffler Spring	1
03310	Clutch Driver	1	03337	Bolt, 3/8	2
03311	Clutch Drum Assy.	1	03338	Muffler	1
03312	Ball Bearing	4	03339	Spark Arrestor	1
03313	Snap Ring	1	03340	Exhaust gasket	1
03314	Gear Case, Upper	1	03341	Locknut	1
03315	Ball Bearing, Small	2	03342	Flat washer	1
03316	Gear & Pinion	1	03343	Stud, #8	1
03317	Gear & Shaft	1	03344	Hose Clamp	2
03318	Gasket	1	03345	Fuel Line	1
03319	Gear Case, Lower	1	03346	Carburetor Seal	1
03320	Spacer	1	03347	Fuel Tank	1
03321	Snap Ring	1	03348	Foam Filter	1
03322	Bolt	6	03349	Filter Cover	1
03223	Locknut	2	03350	Nut, #10	2
03324	Spark Plug	1	03351	Pre Filter	1
03325	Ignition Switch	1	03387	Blower Assy.	1
03326	Hole Plug	2	03895	Ignition	1
03327	Screw, #10	1	03896	Carburetor	1
03333	Screw, #8	2	90028	Lock washer	6
03334	Screw, #8	2	90237	Flat washer	1
03335	Muffler Guard	1			

Maintenance -- Engine

AIR CLEANER:

IMPORTANT: NEVER RUN ENGINE WITHOUT COMPLETE AIR CLEANER INSTALLED ON ENGINE

- To remove and install filter(s) (see Figure 14)\
Loosen two screws. Remove cover. Remove pre-filter and foam filter. Inspect pre-filter and foam filter for discoloration or dirt accumulation. If either is present, service per below instructions. Clean inside of cover and body thoroughly.
- To service filter(s) (see Figure 14)
Foam Filter: Clean and re-oil every three months or every 25 operating hours. Clean and re-oil daily if use in extremely dusty conditions. Wash in water and detergent solution and squeeze (don't twist) until all dirt is removed. Rinse thoroughly in clear water. Wrap in a clean cloth and squeeze (don't twist) until completely dry. Saturate with engine oil and squeeze to distribute oil and remove excess oil. **Pre-Filter:** Wash in water and detergent solution. Rinse thoroughly in clear water and air dry.
- Reassemble air cleaner as shown in Figure 14.

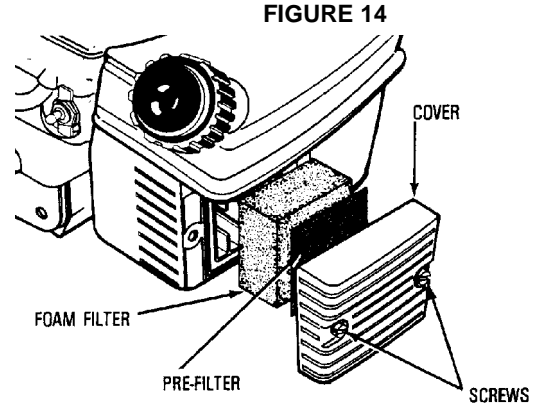

FIGURE 14

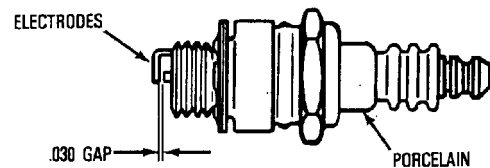

FIGURE 15

SPARK PLUG:

- Check spark plug yearly or every 100 operating hours.
- Clean around spark plug. remove and inspect spark plug (Figure 15).
- Replace spark plug if electrodes are pitted, burned, or porcelain is cracked. Use Champion CJ-Y6 or equivalent.
- Check electrode gap with a wire feeler gauge and set gap at .030" if necessary.
- Install spark plug and tighten securely

MUFFLER AND CYLINDER EXHAUST PORTS

The muffler and cylinder exhaust ports require cleaning after every 75-100 hours of operation. For this maintenance procedure, we recommend that you take your engine to a Hougen Authorized TRAK-STAR Repair Center or your Tecumseh Registered Service Dealer.

COOLING SYSTEM: (FIGURE 16)

Important: Frequently remove debris from cooling fins, air intake screen, and levers and linkage. This will help ensure adequate cooling and correct engine speed.

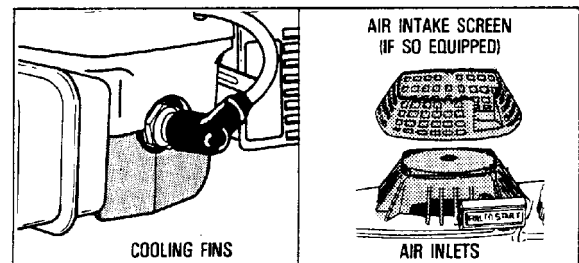

Figure 16

Maintenance -- Drill

In order to minimize wear on moving parts and insure smoother operation and longer life, the following maintenance should be done periodically, based on use.

- At intervals of 500 holes or 10 hours of actual running time, check all fasteners for tightness and retighten if necessary. This is especially important for fasteners required for smooth, efficient cutting action. These include: Gib screws and nuts, engine hold down screws, skid plate screws, bracket mounting screws and nuts, housing bolts, clamp screw and front support bracket bolts.
- Coolant bottle must be attached to inducer under pressure with shut-off valve open to lubricate inducer o-rings whenever engine is running.
- Apply grease to slide dovetails, brass gibs, and the feed gear rack. (For best results, use Shell Cyprina-RA or equivalent.)
- Remove front support bracket from arbor and pack bearing with grease. (Shell Cyprina-RA or equivalent)

Hints for Smoother Operation

1. The centrifugal clutch of the TRAK-STAR Gas Rail Drill requires a break in period of approximately 25-50 cutting cycles. The unit should be allowed to run for 15 to 20 seconds prior to attempting any cutting.
2. Keep inside of TRAK-STAR cutter clear of any chips. Chips will interfere with cutting to maximum depth as well as impede free coolant flow from arbor to work and can cause cutter breakage.
3. Keep slide dovetails, brass gibs, and feed rack lubricated and free of chips and dirt.
4. Tighten all bolts regularly.
5. Keep workpiece, machine, arbor and TRAK-STAR cutter free of chips and dirt.
6. For best operation and longest tool life, use TRAK-STAR cutting fluid mixed at proper ratios.
7. With engine off and spark plug wire disconnected, depress pilot occasionally to check metering of coolant flow. Lack of coolant may cause cutter to freeze in cut, slug to stick, and poor cutter life.

Super Concentrate Cutting Fluid

A good flow of cutting fluid to the tool is important. It cools and lubricates the cutting edge, helps evacuate the chips, keeps the slug from expanding, and helps eject the slug. Various mineral and sulphur base oils are quite popular, however, water base solutions have better cooling qualities.

Listed is our own recommended Concentrated Cutting Fluid For TRAK-STAR Cutters and similar cutting tools. It is a water soluble, biodegradable product. This cutting fluid contains no ingredients that are on the U.S. Government Hazardous Materials List. It is a super concentrated form that will require a 10:1 mixture of water.

Order Number	Size Description
11741-12	12 Pints*
11742-4	4 Gallons**
11743	5 Gallons+
* MEASURED AMOUNT OF CONCENTRATE. COMES IN 12-1 PINT CONTAINERS	
** MEASURED AMOUNT OF CONCENTRATE. COMES IN 4-1 GALLON CONTAINERS AND WILL MAKE 44 GALLONS OF USABLE CUTTING FLUID	
+ COMES IN 5-GALLON CONTAINER, FULL, WILL MAKE 55 GALLONS OF USABLE CUTTING FLUID	

“15,000-Series” TRAK-STAR Disposable Rail Cutters

Premium H.S.S. with Titanium Nitride Coating

Hougen TRAK-STAR Rail Drills are designed to use Hougen TRAK-STAR Rail Cutters, and to achieve maximum efficiency from your unit, we recommend that no substitutes be used.

- ** “15,000-Series TRAK-STAR Cutters are economical and disposable --- there is no need to sharpen --- however it is possible. Tools can be sharpened 2 to 3 times. Send cutters to HMI to the attention of the Resharpener Department.
- ** TRAK-STAR cutters have been shown to drill holes in rails up to 4X faster than twist drills or spade drills, and they produce clean, round, burr-free holes without the need to chamfer.
- ** Multiple cutting edge design, along with proper coolant flow, produces a cool cut raising the rail temperature in the hole no more than 25°F above ambient temperature. This prevents work hardening, stress cracking, service failures, and repeated repairs.

Cutter size, inches	Dec. Equivalent	Part Number
7/8	0.8750	15128
15/16	0.9375	15130
1	1.0000	15132
1 1/16	1.0625	15134
1 1/8	1.1250	15136
1 3/16	1.1875	15138
1 1/4	1.2500	15140
1 5/16	1.3125	15142
1 3/8	1.3750	15144
1 7/16	1.4375	15146
1 1/2	1.5000	15148
Pilot for "15,000-Series" Cutters		03635

Other Products offered by Trak-Star®

Modern, high speed railways and welded rails call for modern, high precision rail equipment. Today track maintenance involves cutting out sections of worn rail, welding in re-placements and grinding the welds smooth afterwards. Because welded rails are subject to considerable tension as the temperature fluctuates, every cut has to be at a perfect right-angle if the rail is to withstand the stress involved and avoid displacement or failure. The same applies to the isolating joints which separate whole sections of rail for automatic signaling purposes, letting the system know exactly where the train is. Rail cutting and welding operations need to be fast, efficient, and frequently with personnel having to swing into action between trains to avoid unnecessary delays. Through our continual commitment, we now offer additional products that will be beneficial to your specific applications.

PARTNER® MODEL K-1250 RAIL GAS-POWERED RAIL SAW

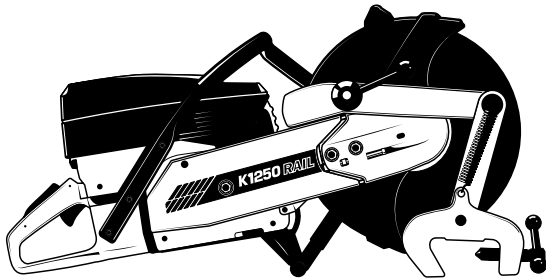

- 7.8 H.P., 2 Cycle Gas Powered
- Smart Carb™ Technology which, insures maximum performance at all times.
- Triple Air Filtration reducing wear and tear, helping minimize maintenance costs
- Precision Clamp, insuring every cut is at a right angle, every time
- Well balanced - ergonomic handles and improved anti-vibration system enables operator to produce quick and easy cuts with less fatigue.
- Trak-Star part number: **K1250RAIL**

PARTNER® MODEL HP 40 HYDRAULIC POWER PACK

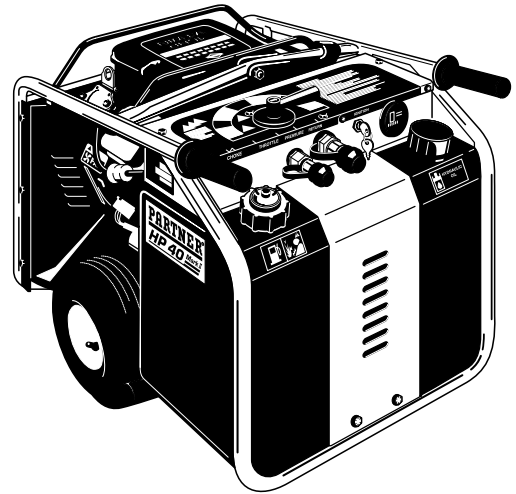

- 16 H.P Gas Powered
- Maximum 2000 PSI with three different flow rates of 10, 8, and 5 GPM
- Compact Design
- Well balanced
- Easily transported by one person
- Automatic Power-up on demand
- Trak-Star part number: **HP40**

Commercial / Industrial Limited Warranty

Hougen Manufacturing, Incorporated warrants its Trak-Star Rail Drills and Portable Magnetic Drills for one (1) year and its Electro-hydraulic Hole Punchers and other products for ninety (90) days from date of purchase against defects due to faulty material or workmanship and will repair or replace (at its option) without charge on any items returned. This warranty is void if the item has been damaged by accident or unreasonable use, neglect, improper service, or other causes not arising out of defects in material or workmanship. No other expressed warranty is given or authorized. Hougen Manufacturing, Inc. disclaims any implied warranty of MERCHANTABILITY or FITNESS for any period beyond the expressed warranty and shall not be liable for incidental or consequential damages. Some states do not allow exclusions of incidental or consequential damages or limitation on how long an implied warranty lasts and, if the law of such a state governs your purchase, the above exclusion and limitation may not apply to you. This warranty gives you specific legal rights and you may also have other rights which vary from state to state.

To obtain warranty service, return the item(s), transportation prepaid, to your nearest Factory Authorized Repair Center or to Hougen Manufacturing, Inc. 3001 Hougen Drive, Swartz Creek, Michigan 48473.

THIS WARRANTY IS IN LIEU OF ANY OTHER WARRANTY, EXPRESSED OR IMPLIED, INCLUDING ANY WARRANTY OF MERCHANTABILITY OR FITNESS FOR A PARTICULAR PURPOSE.

© 2001 Hougen Manufacturing, Inc.

FACTORY AUTHORIZED WARRANTY REPAIR CENTERS

Hougen Manufacturing, Inc.
3001 Hougen Drive
Swartz Creek, MI 48473
(866) 245-3745

Kenbil Service Co.
2900 Adams Street B-15
Riverside, CA 92504
(909) 689-6633

HOUGEN PATENT NOTICE

This product and accessories are covered by one or more of the following U.S. patents, patents pending, and foreign patents: D365,581 5,944,460

Photographs and Specifications shown are accurate in detail at time of printing. Manufacture reserves the right to make improvements and modifications without prior notice.

Hougen, Hougen-Edge, Trak-Star, and Punch-Pro are propriety trademarks of Hougen Manufacturing, Inc. Ogura and the Ogura logo are proprietary trademarks of Ogura & Co., Ltd.



Hougen Manufacturing, Inc.

P.O. Box 2005 • Flint, MI 48501-2005
3001 Hougen Drive • Swartz Creek, MI 48473
Phone: (866) 245-3745 • Fax (800) 309-3299
E-Mail: info@hougen.com
Online: www.trak-star.com



Hougen Manufacturing has received the
Association of American Railroads
Quality Assurance Program Certification

